

## ◆ KSFP10-0031SL20X

10Gb/s SFP+ 1310nm Duplex 20Km Transceiver

### PRODUCT FEATURES

- Up to 10Gb/s data links
- DPB laser transmitter and PIN photo-detector
- Up to 20Km transmission on SMF
- Hot-pluggable SFP footprint
- Duplex LC/UPC type pluggable optical interface
- Low power dissipation
- Metal enclosure, for lower EMI
- RoHS compliant and lead-free
- Single +3.3V power supply
- Support Digital Diagnostic Monitoring interface
- Compliant with SFF-8472
- Case operating temperature  
Commercial: 0°C to +70°C  
Industrial: -40°C to +85°C



### Applications

- 10GBASE-LR/LW Ethernet
- SDH/SONET Application
- 10G FC

## Product Description

The SFP+ transceivers are high performance, cost effective modules supporting multi data-rate of 10Gbps and 20Km transmission distance with SMF. The transceivers are compatible with SFP+ Multi-Source Agreement (MSA) , For further information, please refer to SFP+ MSA.



## Product Selection

Part Number	Operating Case temperature	DDMI
KSFP10-0031SL20C	Commercial(0~70°C)	Yes
KSFP10-0031SL20I	Industrial(-40~85°C)	Yes

## Pin Descriptions

Pin	Symbol	Name/Description	NOTE
1	VEET	Module transmitter ground	1
2	Fault	Module transmitter Fault	2
3	Disable	Transmitter Disable; Turns off transmitter laser output	3
4	SDL	2 wire serial interface data input/output (SDA)	4
5	SCL	2 wire serial interface clock input (SCL)	4
6	MOD-ABS	Module Absent, connect to VeeR or VeeT in the module	2
7	RS0	Rate select0: module inputs and are pulled low to VeeT with >30 kΩ resistors in the module.	
8	LOS	Receiver Loss of Signal Indication	
9	RS1	Rate select1: module inputs and are pulled low to VeeT with >30 kΩ resistors in the module.	
10	VeeR	Module receiver ground	1
11	VeeR	Module receiver ground	1
12	RD-	Receiver inverted data out put	
13	RD+	Receiver non-inverted data out put	
14	VeeR	Module receiver ground	1
15	VccR	Module receiver 3.3V supply	
16	VccT	Module transmitter 3.3V supply	
17	VeeT	Module transmitter ground	1
18	TD+	Transmitter non-inverted data out put	
19	TD-	Transmitter inverted data out put	
20	VeeT	Module transmitter ground	1

Notes:

1. The module ground pins shall be isolated from the module case.
2. This pin is an open collector/drain output pin and shall be pulled up with 4.7K-10Kohms to Host\_Vcc on the host board.
3. This pin shall be pulled up with 4.7K-10Kohms to VccT in the module.
4. This pin is an open collector/drain output pin and shall be pulled up with 4.7K-10Kohms to Host\_Vcc on the host board.

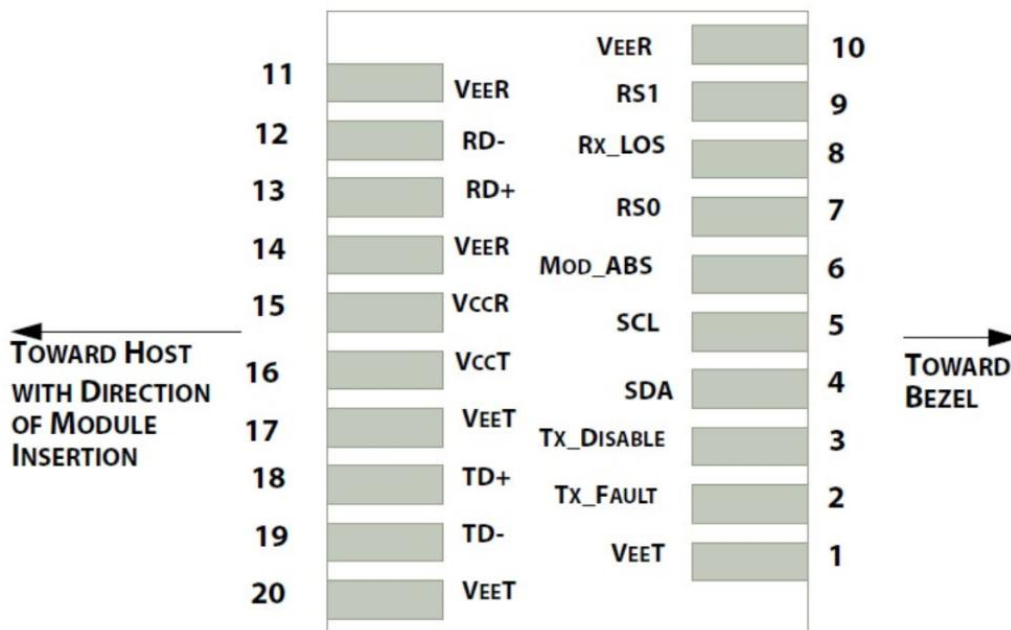

Figure2. Pin out of Connector Block on Host Board

## Absolute Maximum Ratings

Parameter	Symbol	Min.	Typ.	Max.	Unit	Note
Storage Temperature	Ts	-50		+95	°C	
Relative Humidity	RH	5		95	%	
Power Supply Voltage	VCC	-0.3		+4	V	

## Recommended Operating Conditions

Parameter	Symbol	Min.	Typ.	Max.	Unit	Note
Case Operating Temperature	Tc	0		70	°C	Commercial
	Tl	-40		85	°C	Industrial
Power Supply Voltage	Vcc	3.14	3.3	3.47	V	
Power Supply Current	Icc			260	mA	
Data Rate	BR		10		Gbps	
9/125um G.652 SMF	Lmax			20	Km	

## Electrical Characteristics

Parameter	Symbol	Min.	Typ.	Max.	Unit	Note
<b>Transmitter</b>						
Tx Disable Input-High	VDISH	2		Vcc+0.3	V	
Tx Disable Input-Low	VDISL	0		0.8	V	
Tx Fault Input-High	VTxFH	2		Vcc+0.3	V	
Tx Fault Input-Low	VTxFL	0		0.8	V	
<b>Receiver</b>						
LOSS -High	V <sub>LOSH</sub>	2		Vcc+0.3	V	
LOSS -Low	V <sub>LOSL</sub>	0		0.8	V	

## Optical Characteristics

Parameter	Symbol	Min.	Typ.	Max.	Unit	Note
<b>Transmitter</b>						
Average Output Power	POUT	-3		2	dBm	
Extinction Ratio	ER	3.5			dB	
Center Wavelength	$\lambda_c$	1260	1310	1355	nm	DFB Laser
Side Mode Suppression Ratio	SMSR	30			dB	
Transmitter OFF Output Power	Poff			-45	dBm	
<b>Receiver</b>						
Receiver Sensitivity	SENS			-11.4	dBm	1
Receiver Overload		0.5			dBm	
Input Optical Wavelength	$\lambda_C$	1270		1610	nm	PIN-TIA
LOS De-assert	LOSD			-16	dBm	
LOS Assert	LOSA	-25			dBm	2
LOS Hysteresis		0.5	1.0		dB	

**Note:**

1. Class 1 Laser Safety per FDA/CDRH and IEC-825-1 regulations.
2. Measured with a PRBS  $2^{31}-1$  test pattern, @10Gb/s, BER< $10^{-12}$ .

## EEPROM Information

EEPROM memory map specific data field description is as below:

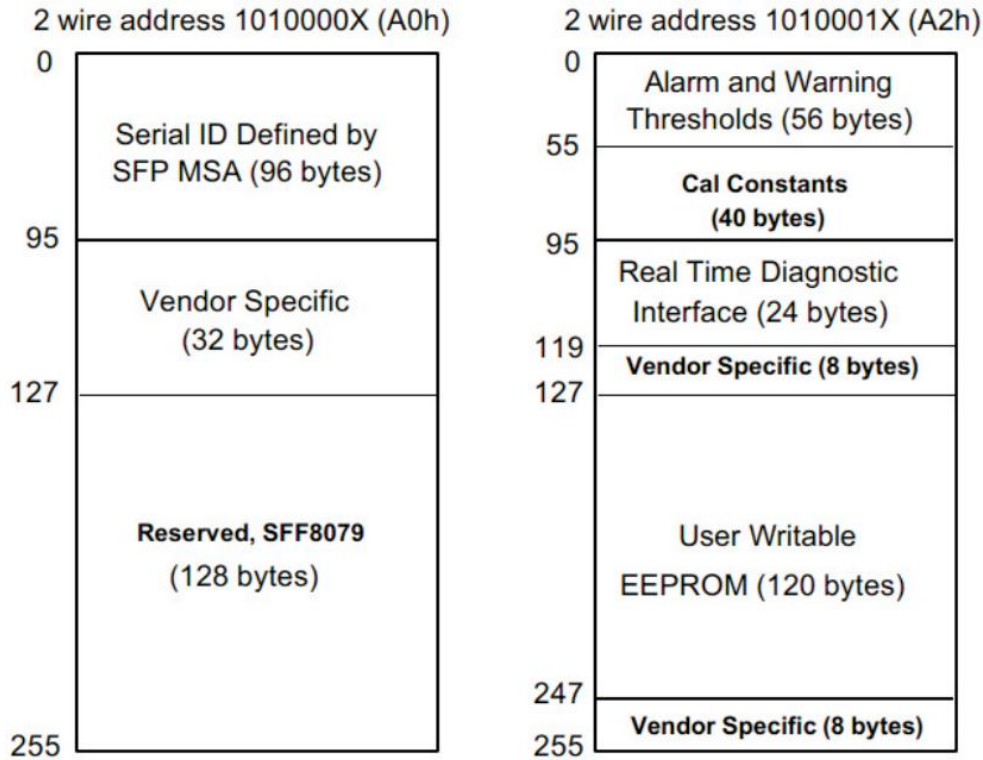

## Digital Diagnostic Monitoring Interface

Five transceiver parameter values are monitored. The following table defines the monitored parameter's accuracy.

Parameter	Range	Accuracy	Calibration
Temperature	0 to +70°C (C)	±3°C	Internal
	-40 to +85°C (I)		
Voltage	2.97 to 3.63V	±3%	Internal
Bias Current	0 to 100mA	±10%	Internal
TX Power	-15 to 0dBm	±3dBm	Internal
RX Power	-25 to 0dBm	±3dBm	Internal

## Recommend Circuit Schematic

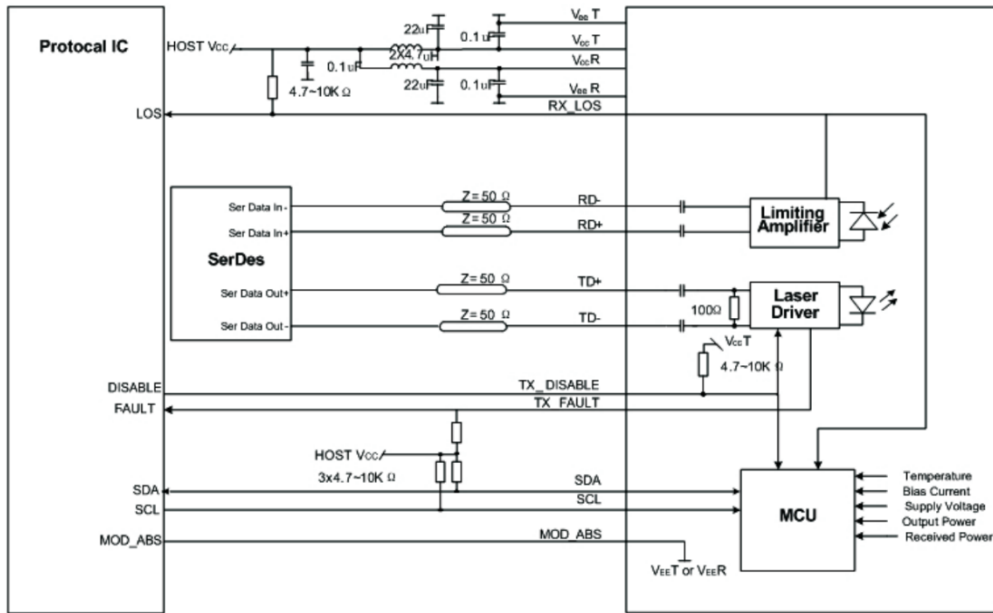

## Mechanical Specifications

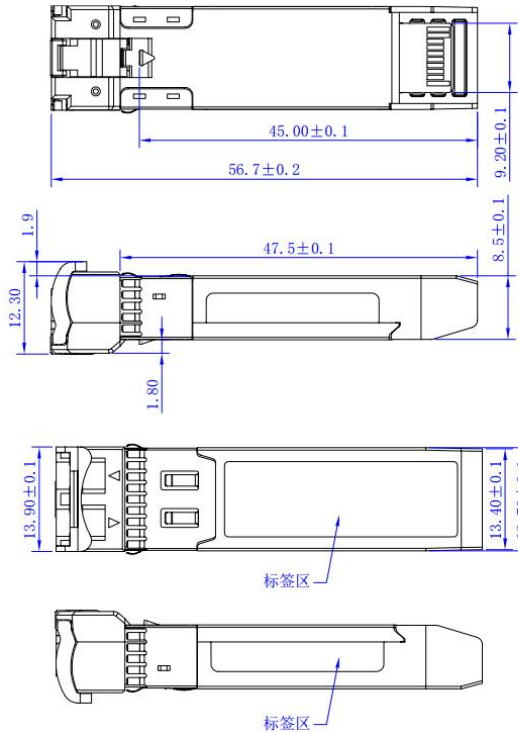

Units:mm

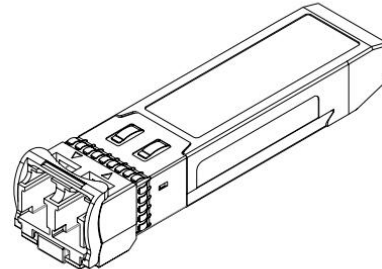
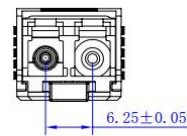



## Revision History

Revision	Initiated	Reviewed	Approved	DCN	Release Date
Version1	Zhangchengxing	Pengyanhui	Liubin	New Released.	July 28, 2017
Version1.1	Hugang	Pengyanhui	Liubin	New Released.	Dec 17,2020